

category	<b>vibration isolation</b>
description	<b>VT</b>



VT Ceiling mounts designed for the suspension of false acoustic ceilings and machinery operating at more than 450rpm. These isolators are made from piano tail springs with high mechanical performance.

They incorporate a rubber bush designed to avoid the acoustic bridging.

A robust metal shell supplied with an ant-corrosive zinc-plated coating.

Loads from 10Kg to 750Kg.

TYPE	A	H	B	C	E	M	CODE
VT-25	75	120	30	12	50	M-8	20201
VT-50	75	120	30	12	50	M-8	20202
VT-75	75	120	30	12	50	M-8	20203
VT-100	75	120	30	12	50	M-8	20204
VT-125	75	120	30	12	50	M-8	20211
VT-150	120	160	30	16	80	M-12	20205
VT-200	120	160	30	16	80	M-12	20210
VT-250	120	160	30	16	80	M-12	20206
VT-350	120	160	30	16	80	M-12	20207
VT-500	140	180	30	18	100	M-14	20208
VT-750	140	180	30	18	100	M-14	20209

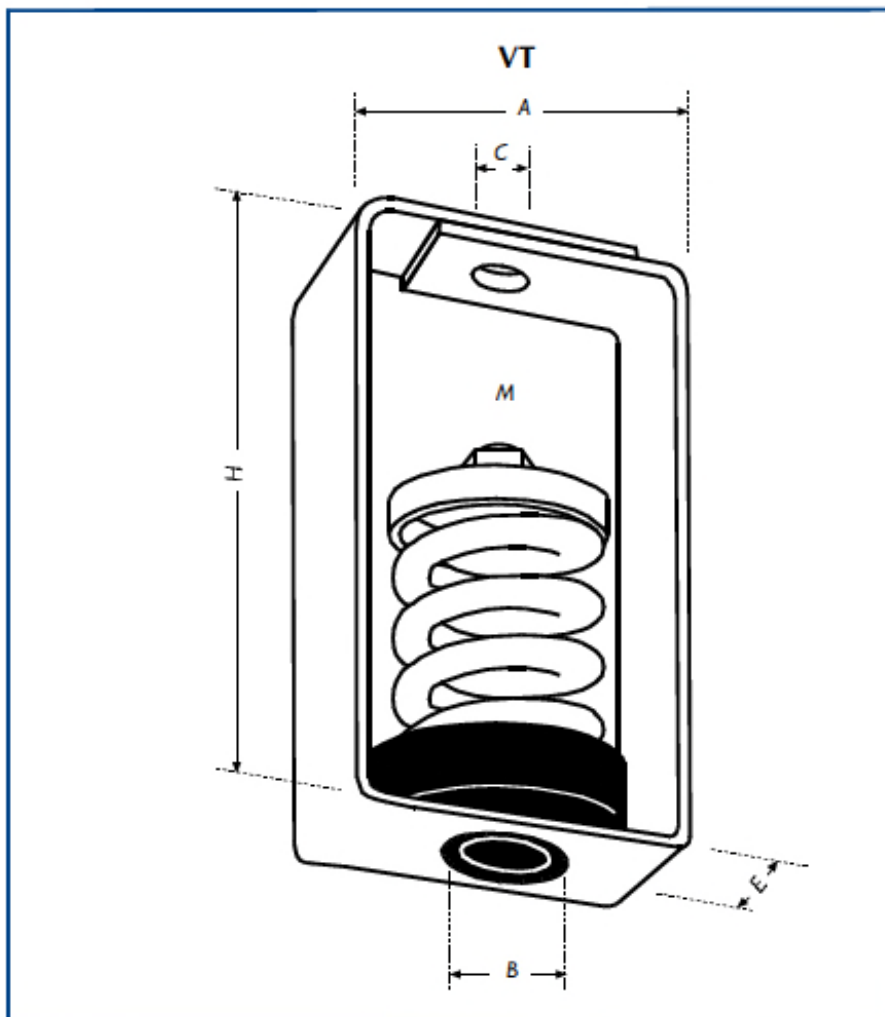

© 2010 Custom Audio Designs Limited: No part of this information sheet may be reproduced in any form without the express written permission of Custom Audio Designs Limited. Check for later versions. All information contained in these details is given in good faith but without warranty. Custom Audio Designs reserves the right to alter the specifications of any product without notice.



